

UMFANGFRÄSEN

PERIPHERAL MILLING



FRÄSERSCHAFT Typ

MILLING SHANK Type

M117U

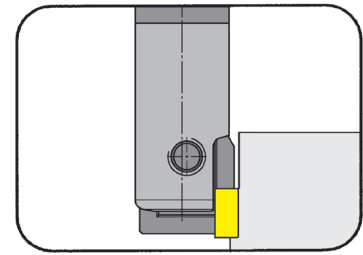

Zylindrischer Hartmetall-Fräaserschaft - schrumpfbar
Cylindrical carbide shank - shrink fit

Schaftmaterial: Hartmetall (schwingungsarm)
Material of shank: Carbide - Giving a good vibration resistance

für Schneidplatte
for use with Insert

Typ S17...U...
Type

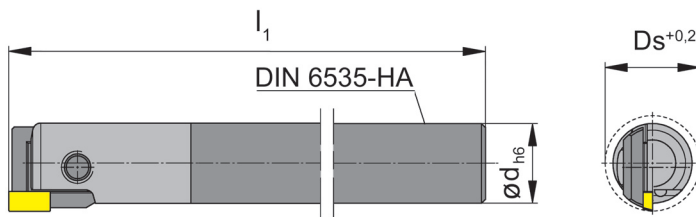

E

Abbildung = rechtsschneidend
Picture = right hand cutting version

Bestellnummer Part number	Ds	l ₁	d	Größe Size
M117U.MD06.08.5.05	8	63	6	05
M117U.MD08.10.5.07	10	77	8	07

Abmessungen in mm
Dimensions in mm

Das Anzugsdrehmoment der Schrauben finden Sie in den Technischen Hinweisen.
For torque specifications of the screw, please see Technical Instructions.

Ersatzteile

Spare parts

Fräaserschaft Milling shank	Spannschraube Screw	TORX PLUS®-Schlüssel TORX PLUS® Wrench
M117U.MD06.08.5.05	030.265P.0818	T8PL
M117U.MD08.10.5.07	2.6.5T8EP	T8PL

UMFANGFRÄSEN PERIPHERAL MILLING



SCHNEIDPLATTE Typ
INSERT Type

S117

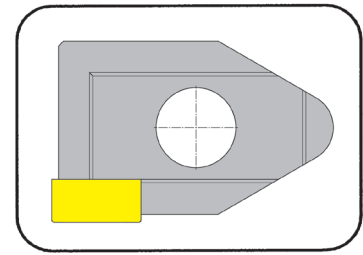

Hochglanzfräsen
High polish milling

für Fräseschaft
for use with Milling shank

Typ M117U
Type

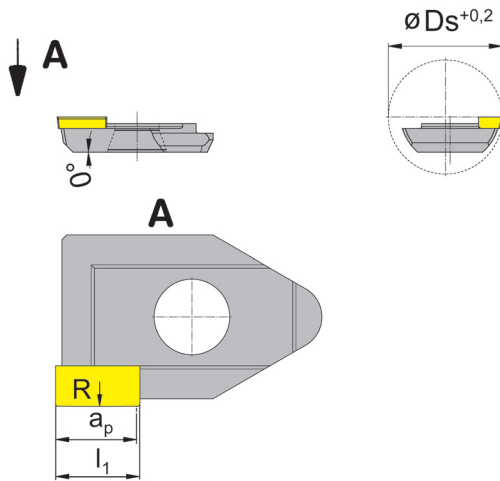

E

Bestellnummer Part number	Ds	R	a _p	l ₁	Ds	Größe Size	MD10	Geometrien für / Geometries for		
								Aluminium Aluminium	Messing Brass	Kunststoffe (PMMA) Synthetics (PMMA)
S117.MD08.4.05U.M0 S117.MD08.4.05U.X0	8	100	4	4,2	8	05	Δ	x	x	x
S117.MD10.5.07U.M0 S117.MD10.5.07U.X0	10	150	5	5,2	10	07	Δ	x	x	x
S117.MD12.5.09U.M0 S117.MD12.5.09U.X0	12	150	5	5,2	12	09	Δ	x	x	x

▲ ab Lager / on stock
Δ 4 Wochen / 4 weeks

Abmessungen in mm
Dimensions in mm

Schneiden nur optisch vermessen!
Cutting edges must be measured optically!